

TORRES DE ACERO 9 X 4 SENCILLA

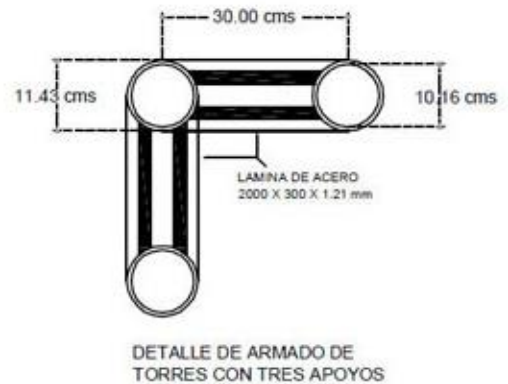
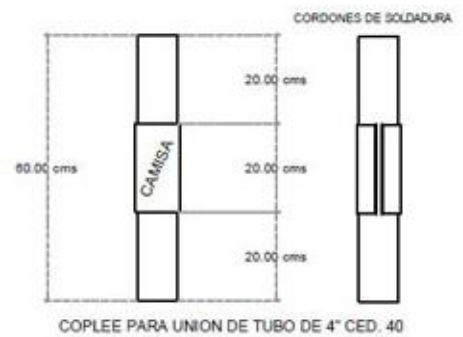
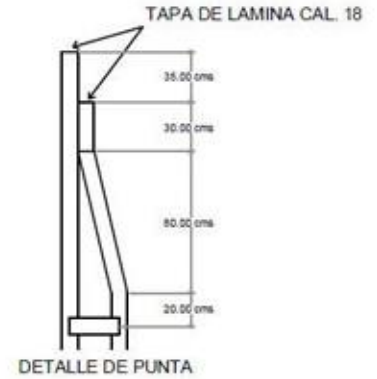
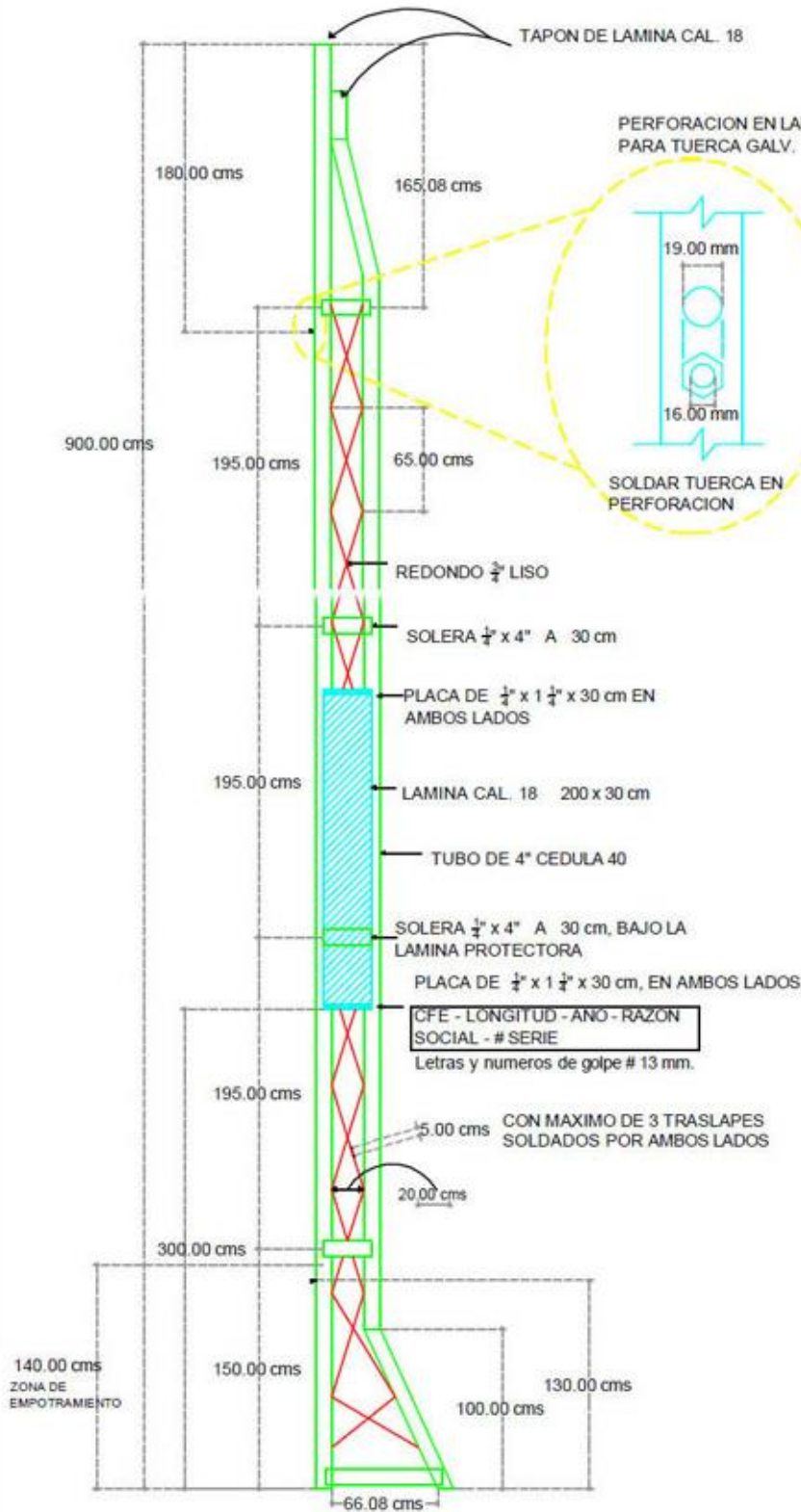

LISTA DE MATERIALES

DESCRIPCION	CANT.
SOLERA $\frac{1}{2}$ " X 1 $\frac{1}{2}$ " X 300 mm.	2 Kgs.
SOLERA $\frac{1}{2}$ " X 4" X 300 mm.	19 Kgs.
REDONDO LISO $\frac{3}{4}$ " A 6100 mm.	42 Kgs.
LAMINA CAL. 18 2000 X 300 mm.	12 Kgs.
TUBO DE 4" CED. 40	290 Kgs.
TUBO DE 3" CED. 40	14 Kgs.

ACOTACIONES EN CMS
SIN ESCALA.