

**TORRES DE ACERO  
9 X 4 DOBLE**

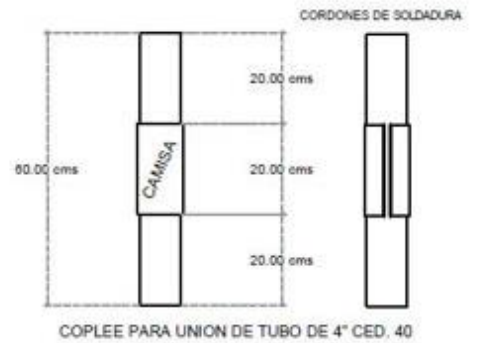
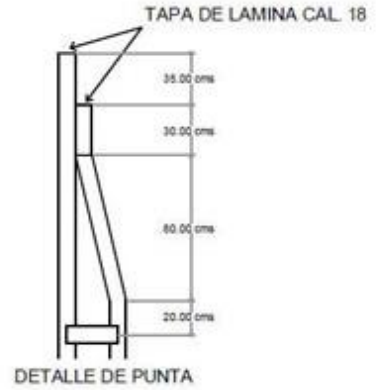
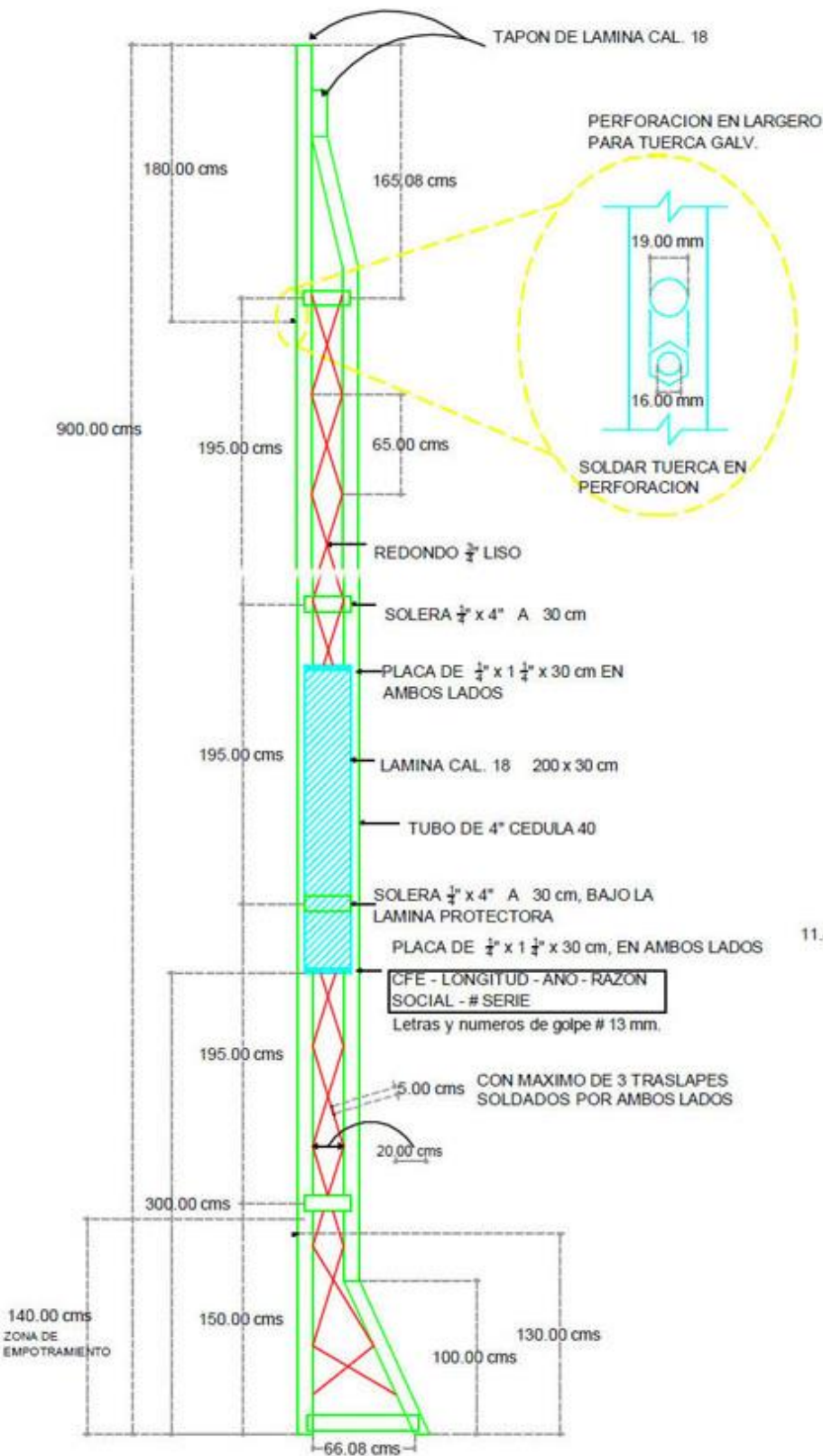

**LISTA DE MATERIALES**

DESCRIPCION	CANT.
SOLERA 1/2" X 1 1/4" X 300 mm.	4 Kgs.
SOLERA 1/2" X 4" X 300 mm.	38 Kgs.
REDONDO LISO 3/4" A 6100 mm.	84 Kgs.
LAMINA CAL. 18 2000 X 300 mm.	24 Kgs.
TUBO DE 4" CED. 40	434 Kgs.
TUBO DE 3" CED. 40	21 Kgs.

ACOTACIONES EN CMS  
SIN ESCALA.